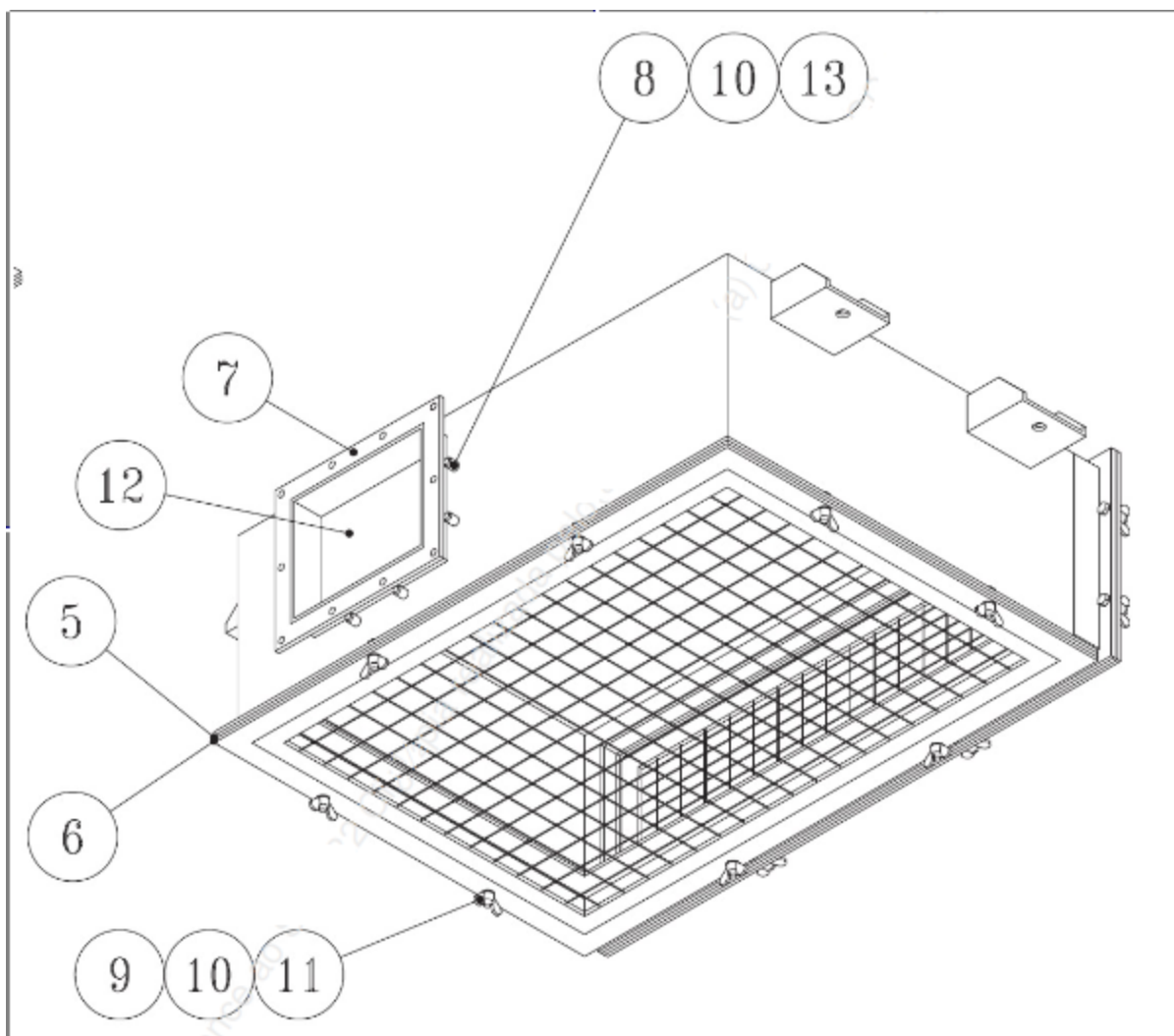




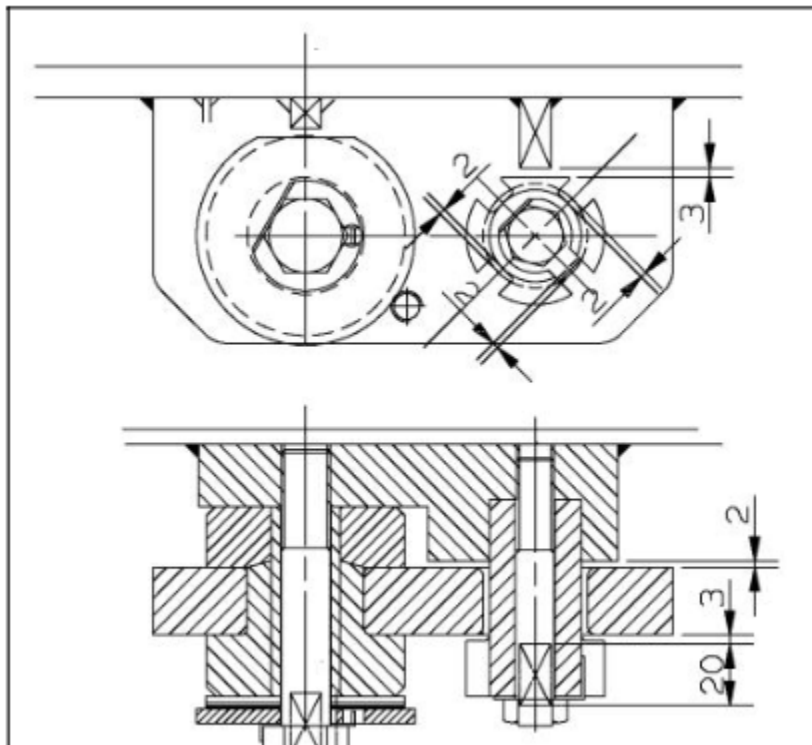
**BRAZILIAN NAVY**  
**NAVY INDUSTRIAL DIRECTORATE**  
**TECHNICAL DRAWING**

**ATTACHMENT A**





ATTACHMENT C



ATTACHMENT D

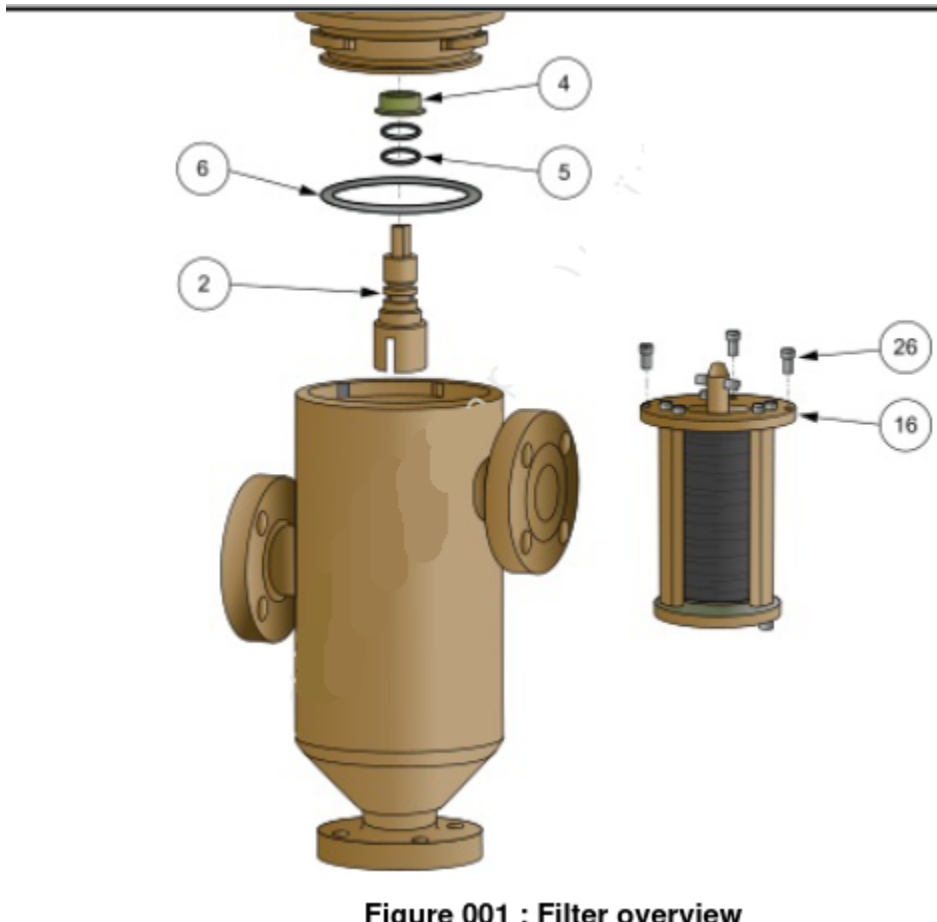
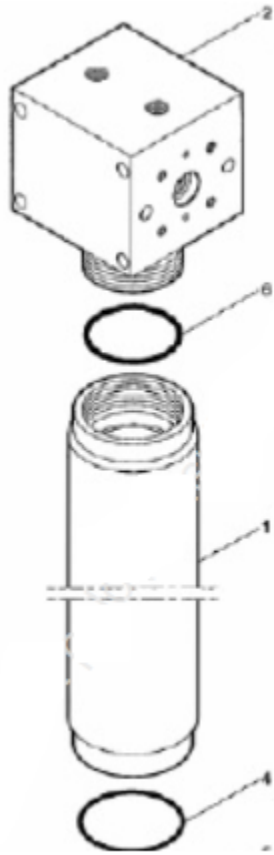
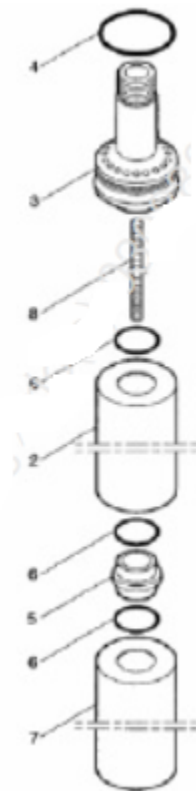
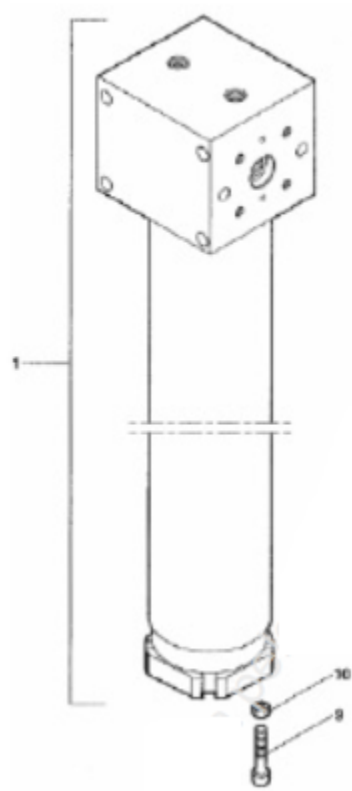
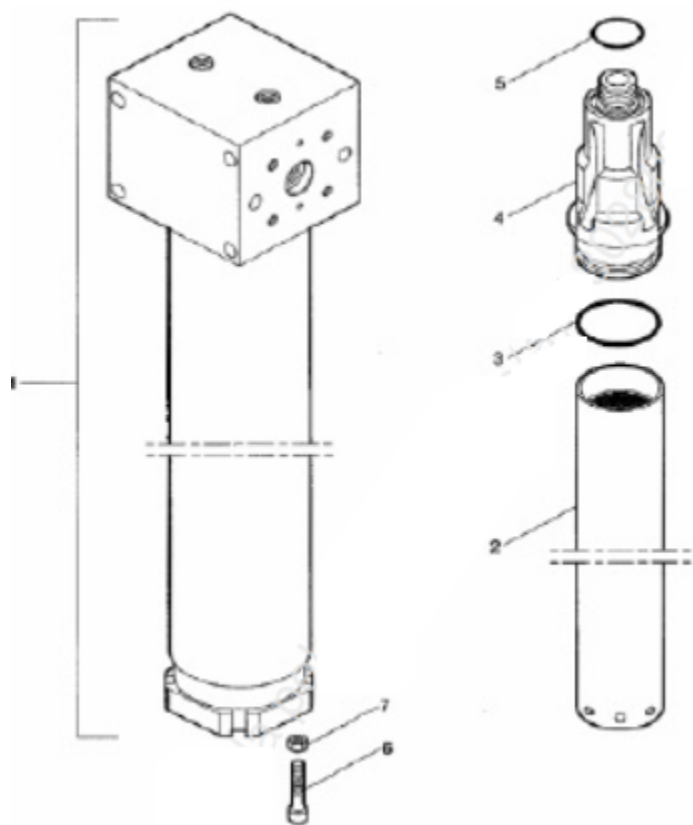


Figure 001 : Filter overview

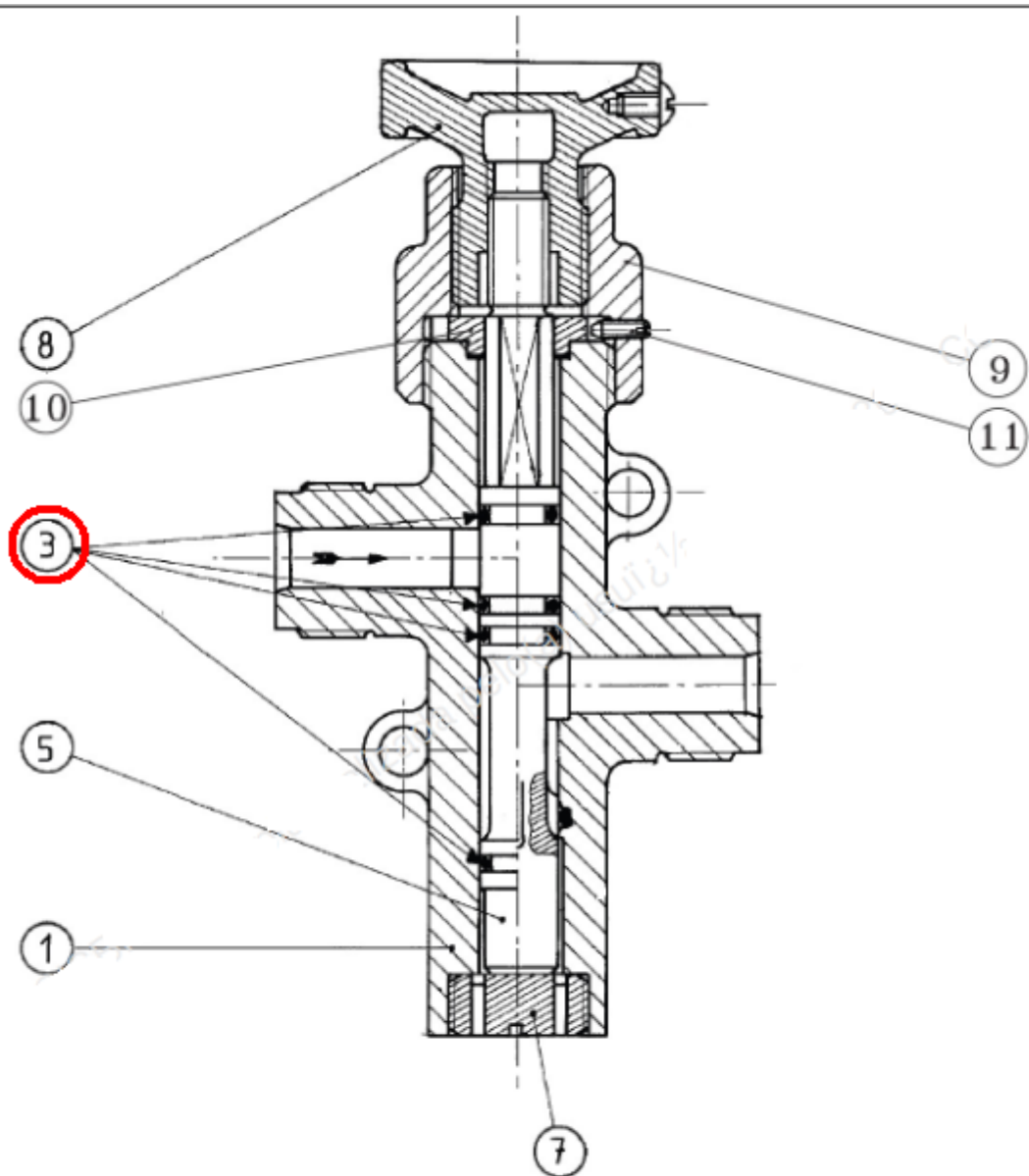
ATTACHMENT E





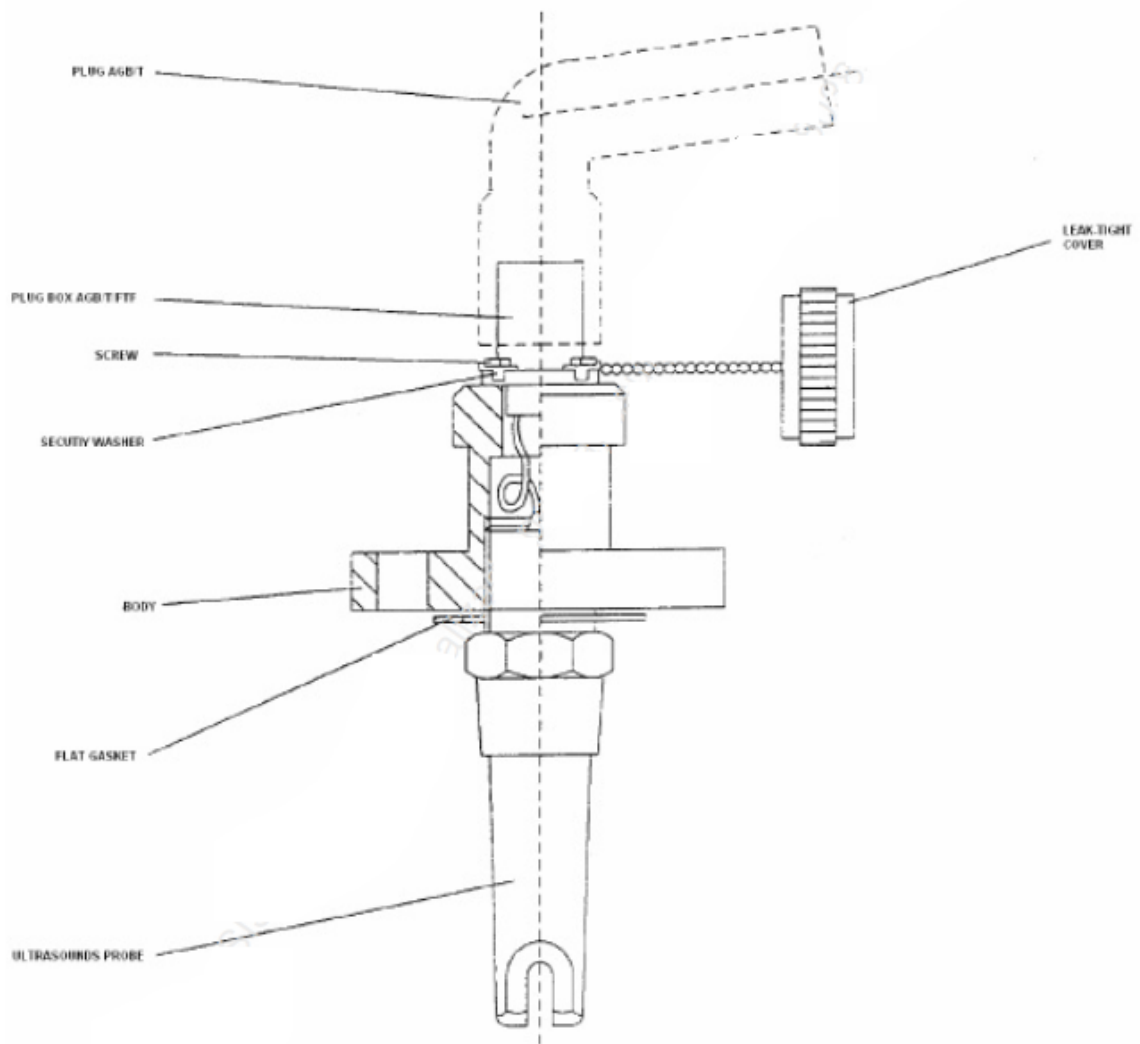


## ATTACHMENT F

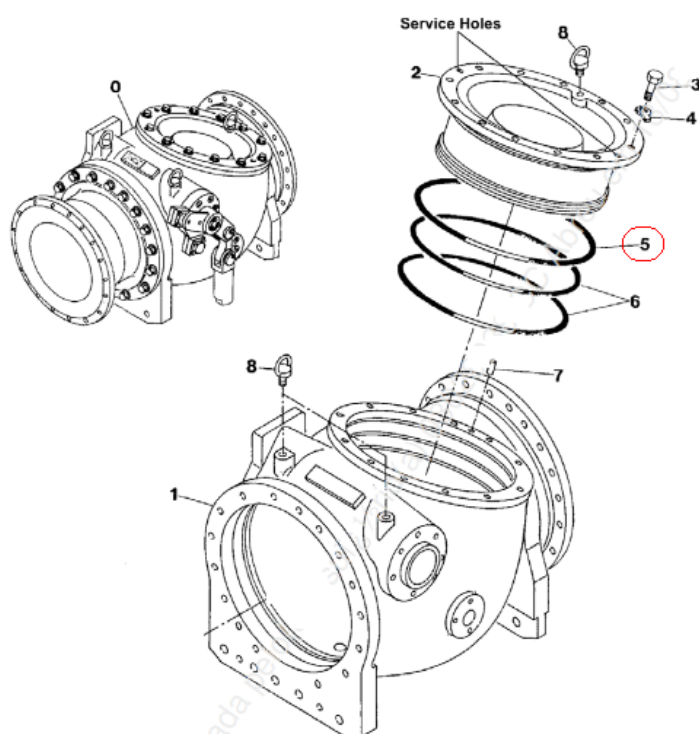


Item/I	Designation	NATO Code	Supplier reference	NSN	Qty
3	VALVE (18RT150D00010)	FAK87	MAT175-0407-18RT150D00010		1
11	. O-RING 10.50X2.70 20A8 GN	F8226	JT 10.50X2.70-20A8	5331145900763	4
	. CONE POINT SCREW	FAK87	MAT175-0407CF12	5305145879987	1

# ATTACHMENT G



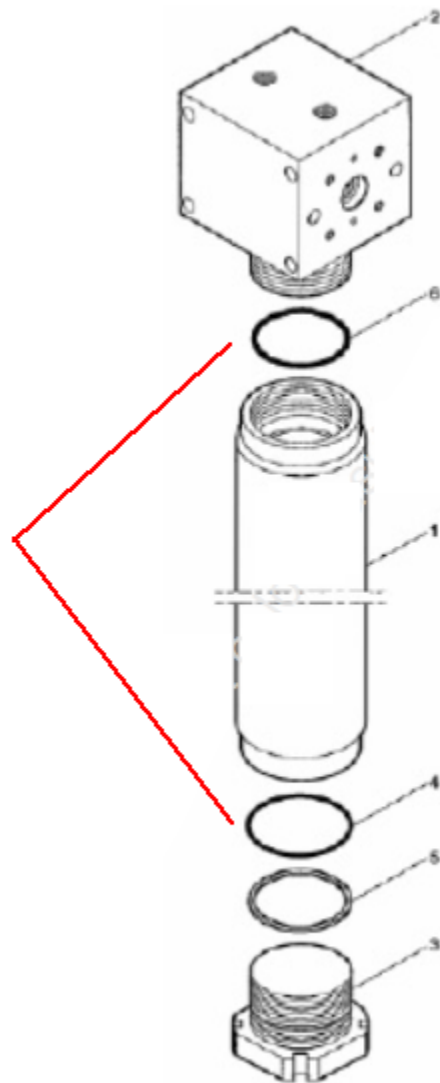
## ATTACHMENT H

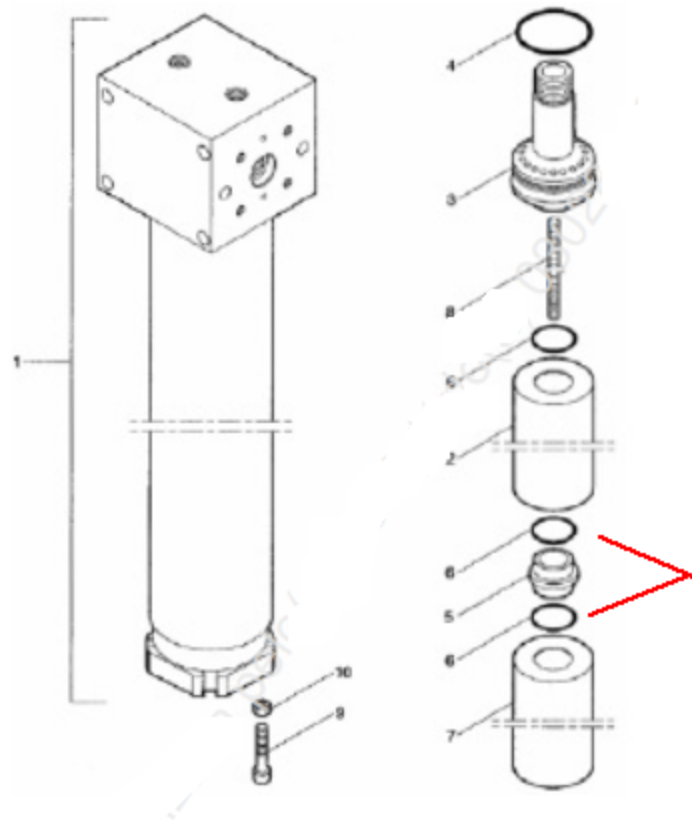


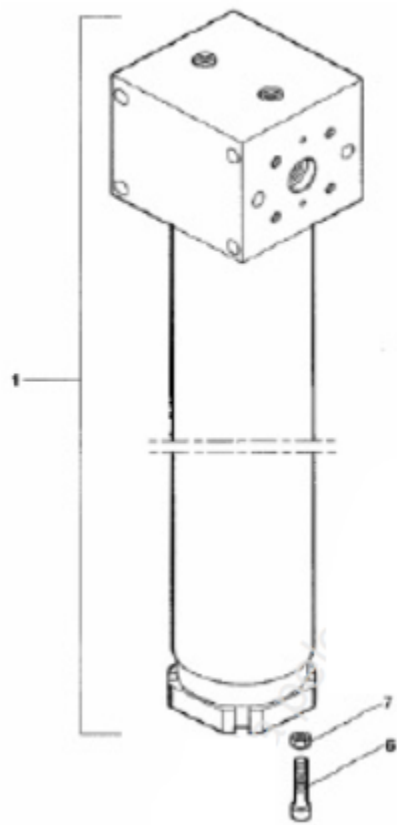
**Table 4.1 – EXTERNAL VALVE, PORT**

REF. FIG.	POS.	DESCRIPTION	CALZONI P/N	MANUFACTURER NAME	MANUFACTURER/STANDARD NUMBER OR CODE	Q.TY
Figure 4.1	0	EXTERNAL VALVE, PORT	D1239889	CALZONI		1
Figure 4.1	1	BODY	D1439585	CALZONI		1
Figure 4.1	2	INSPECTION DOOR	D1440478	CALZONI		1
Figure 4.1	3	SCREW, HEXAGONAL HEAD	D0586667	COM	M16X45, UNI5739, A4-70, UNI7323/8	12
Figure 4.1	4	WASHER	D0568474	COM	17, UNI6600, X5CrNiMo1712, UNI8317 (ASTM A240 TP 316)	12
Figure 4.1	5	O-RING	D0569431	PARKER HANNIFIN	2-279 V747-75 329.79X3.53	1

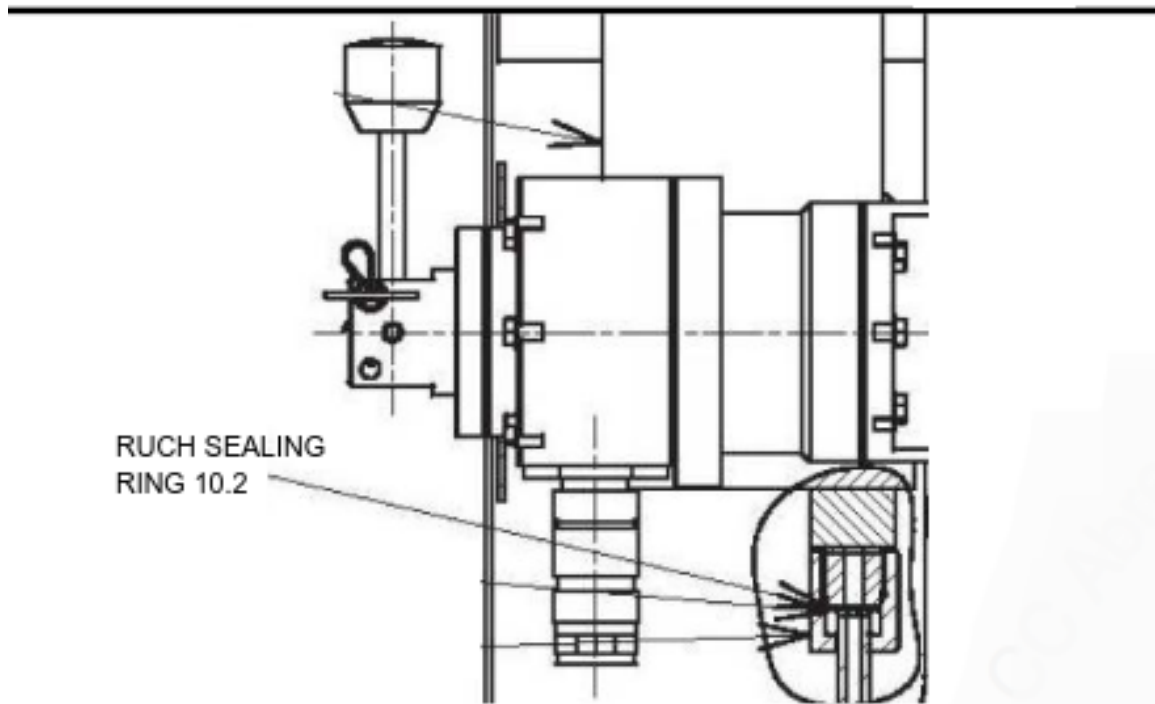
ATTACHMENT I





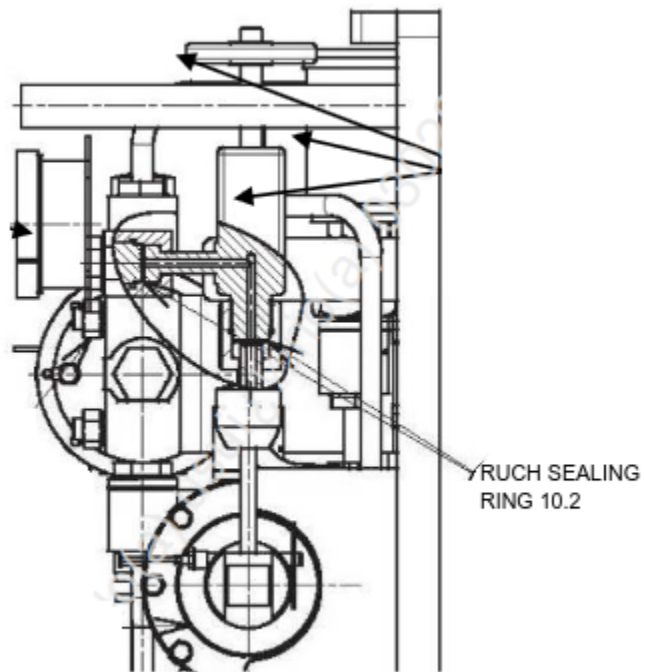


ATTACHMENT J



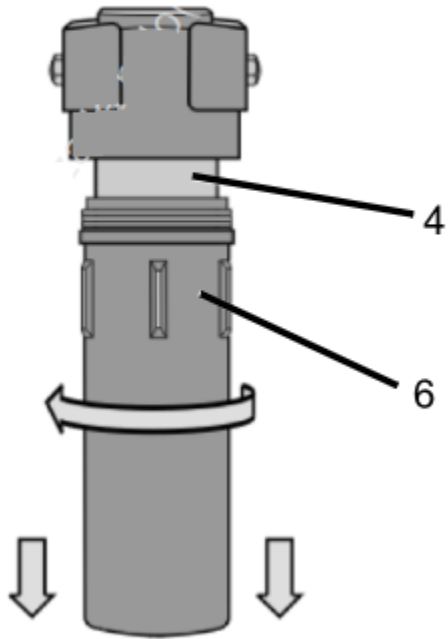
RUCH SEALING  
RING 10.2

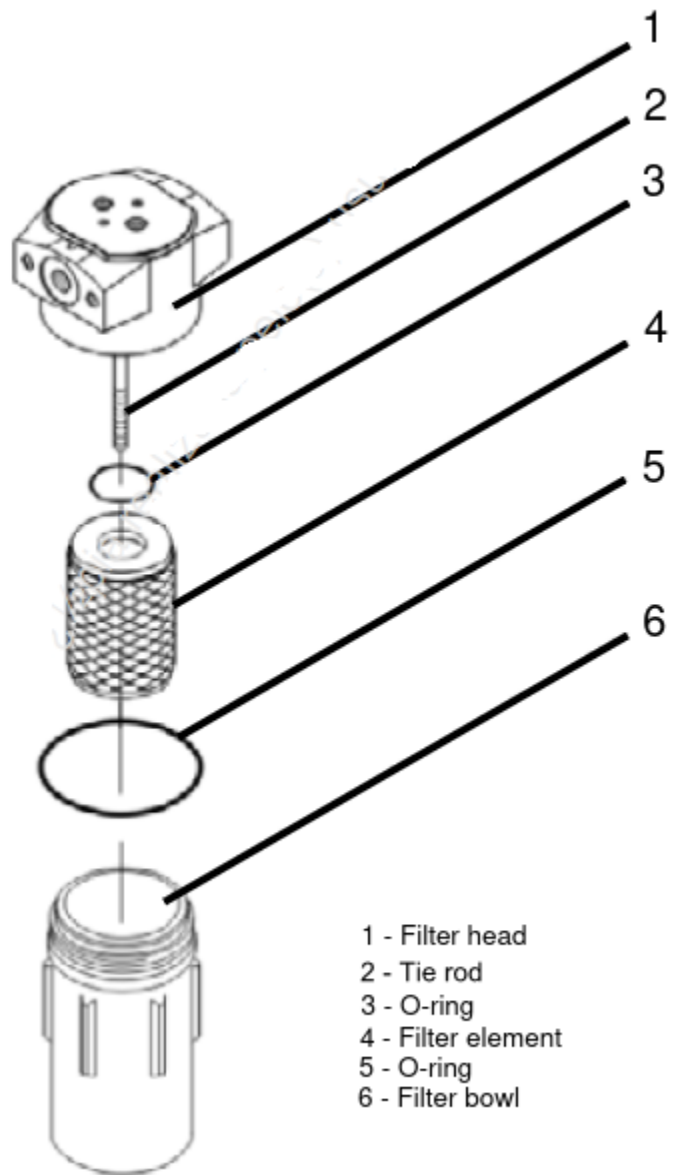
8038 CC A6

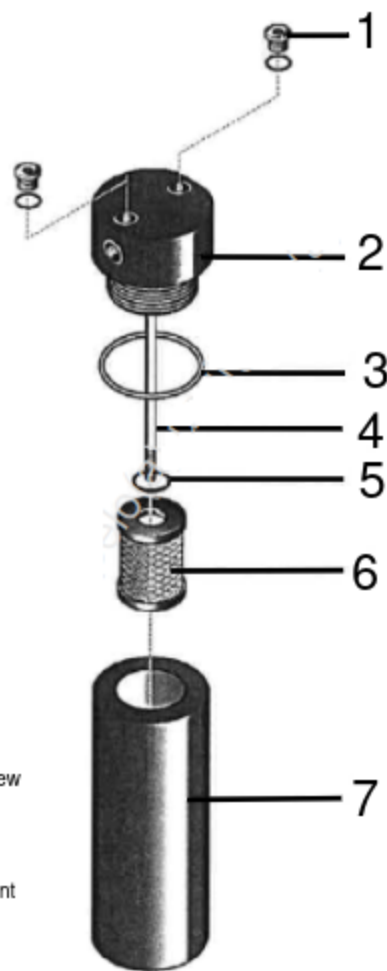


**Figure 5**

ATTACHMENT K

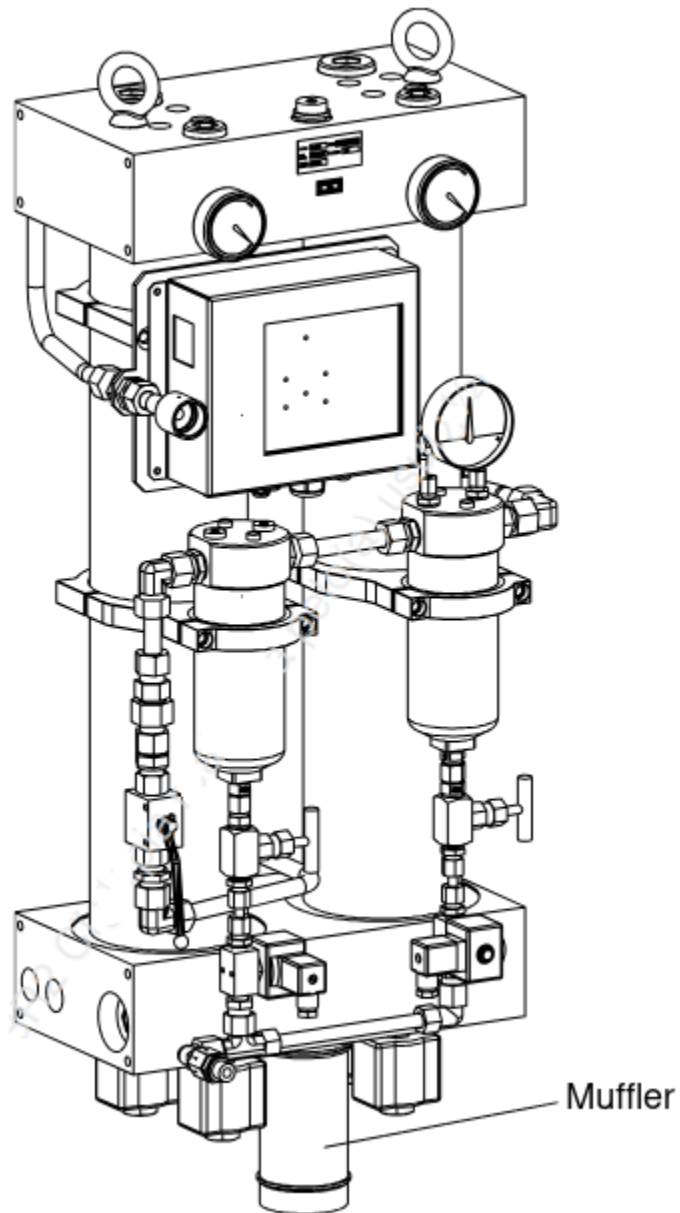




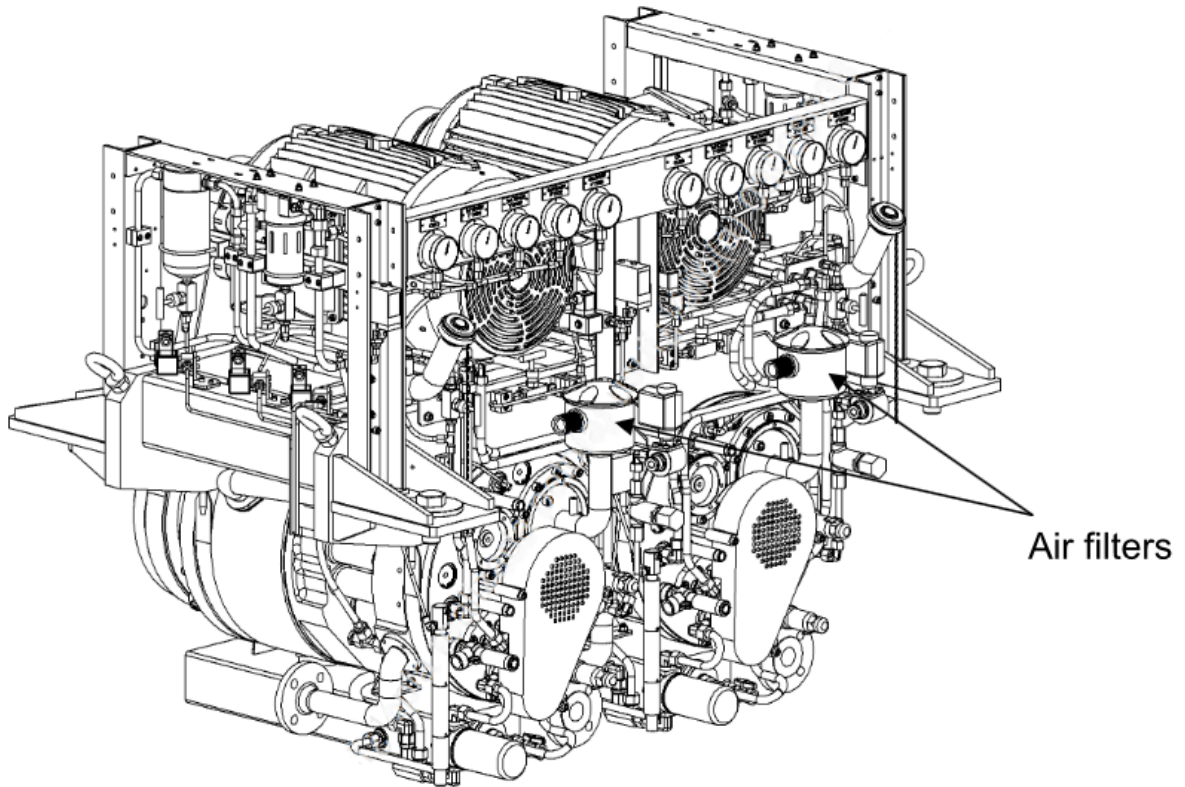


- 1 - Locking screw
- 2 - Filter head
- 3 - O-ring
- 4 - Tie rod
- 5 - O-ring
- 6 - Filter element
- 7 - Filter bowl

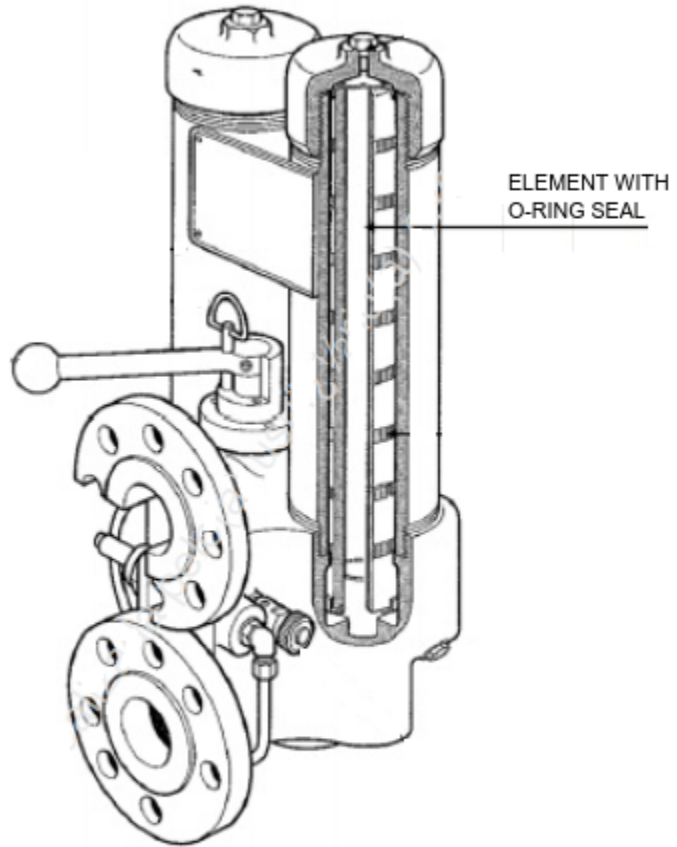
ATTACHMENT L



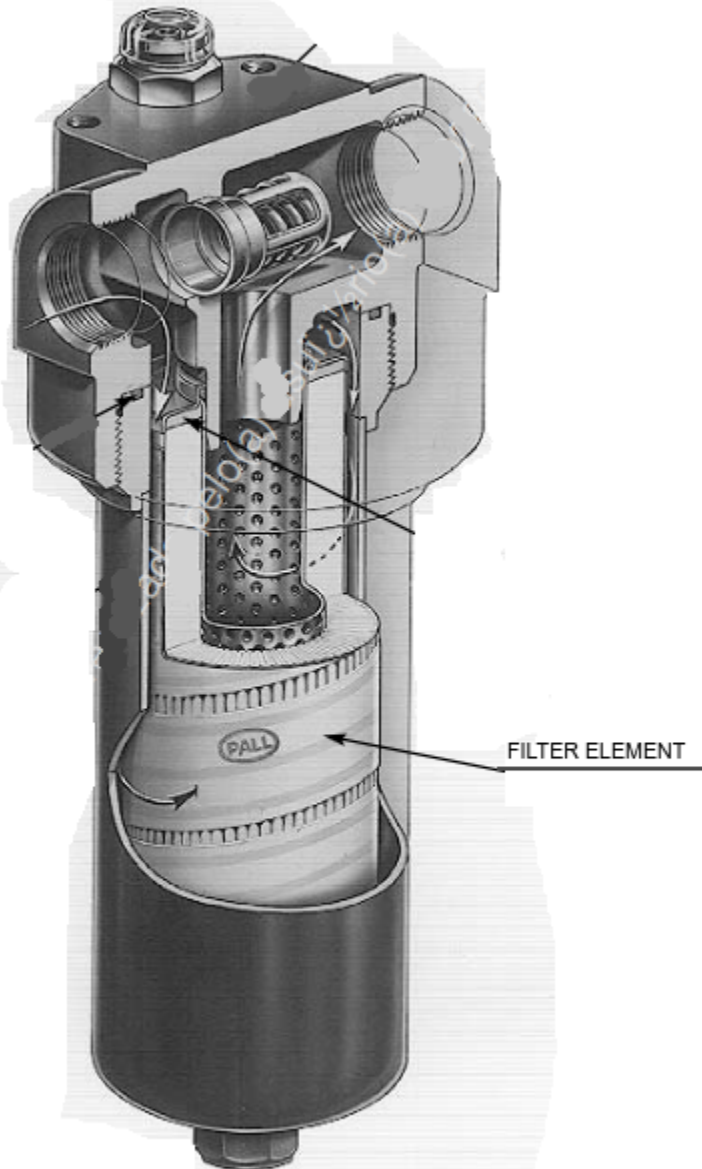
## ATTACHMENT M



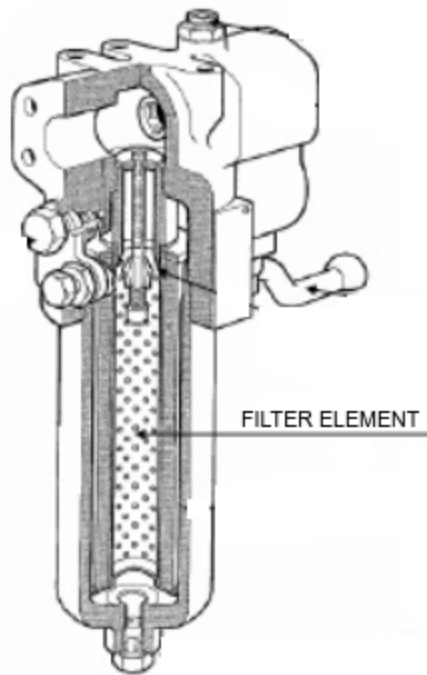
# ATTACHMENT N



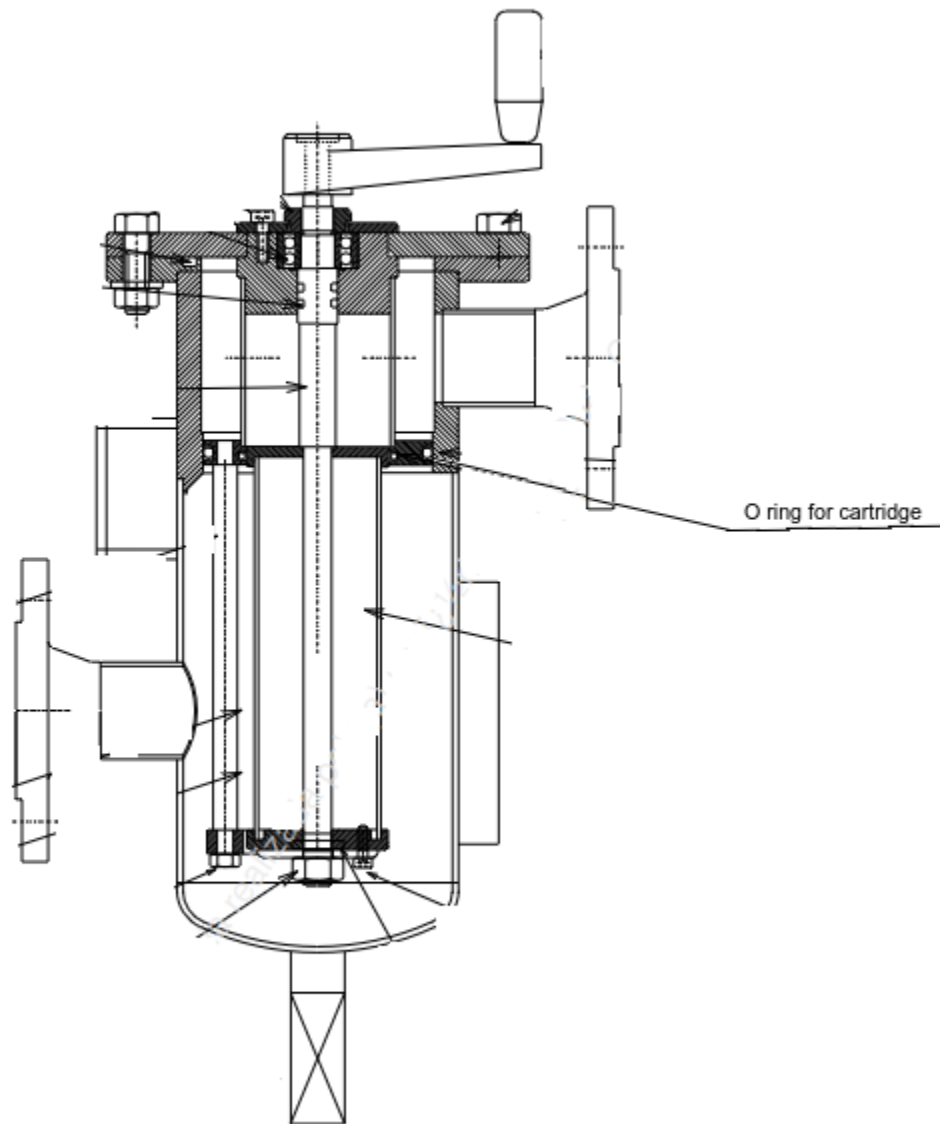
ATTACHMENT O



ATTACHMENT P

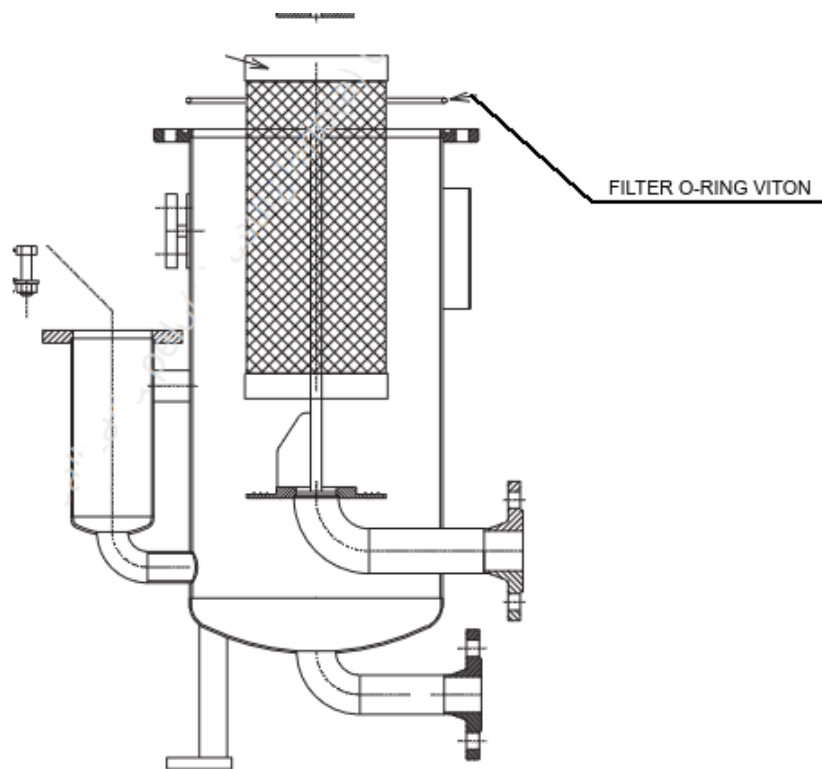


ATTACHMENT Q



**GAS OIL PRE-FILTER**

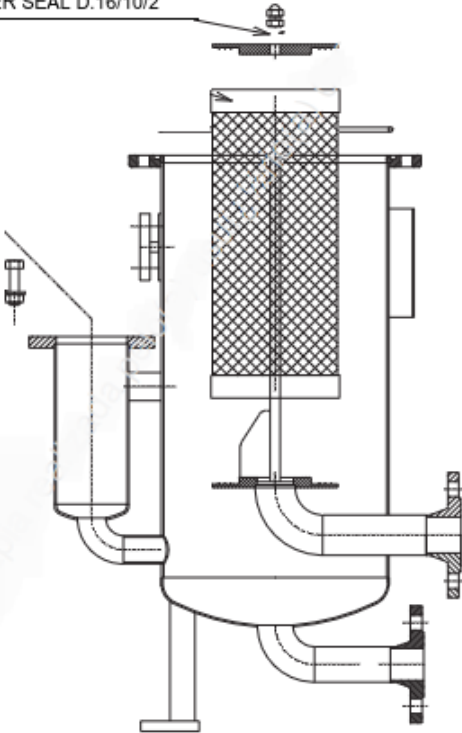
# ATTACHMENT R



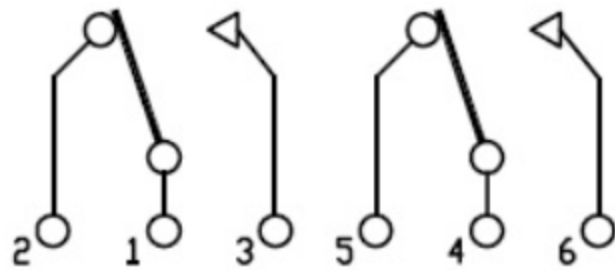
ATTACHMENT S



FIBER SEAL D. 16/10/2



ATTACHMENT T



LEANDRO JUSTINO DE ABREU  
Lieutenant-Commander  
Ship Manager

ASSINADO DIGITALMENTE