

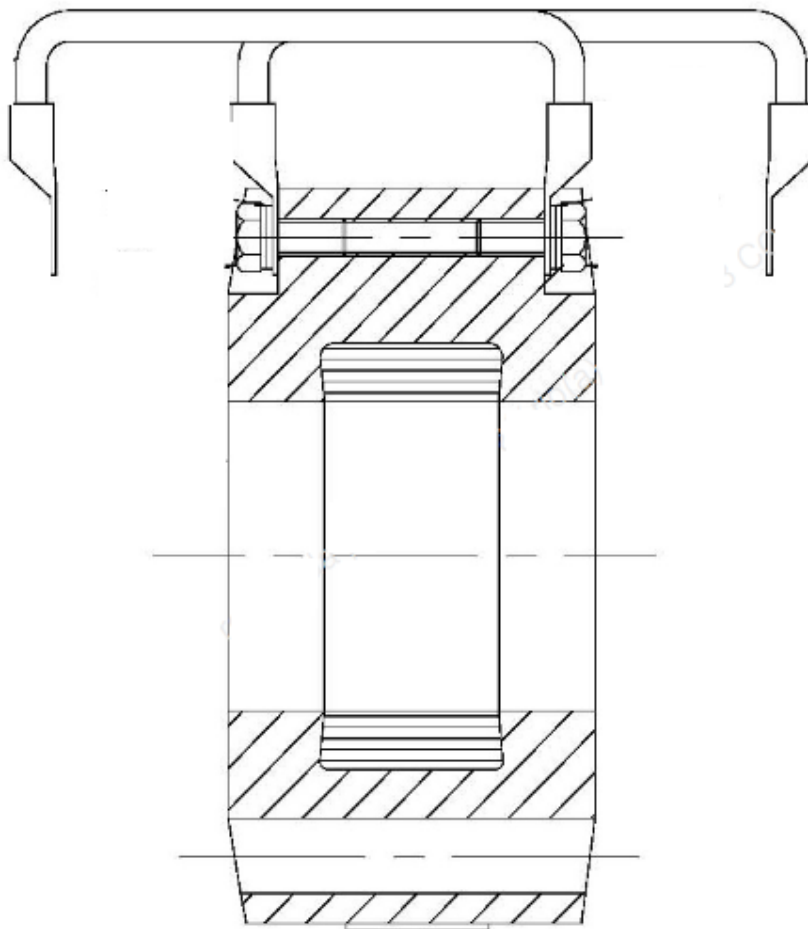

**BRAZILIAN NAVY**  
**NAVY INDUSTRIAL DIRECTORATE**  
**TECHNICAL DRAWING**

**ATTACHMENT A**



# ATTACHMENT B

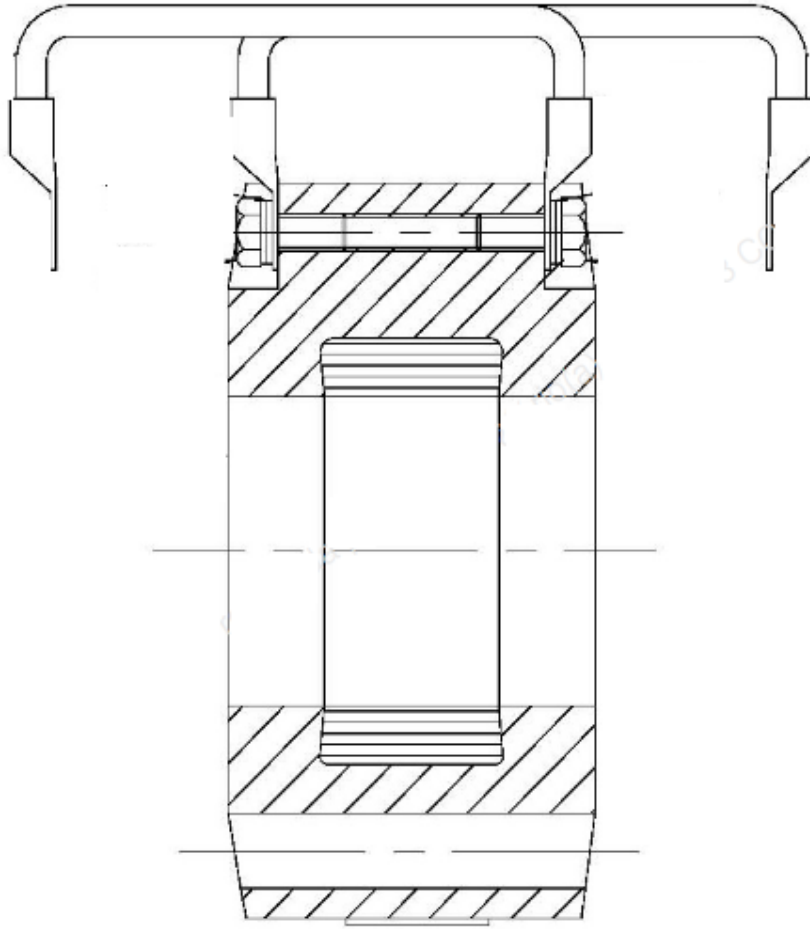

# ATTACHMENT C

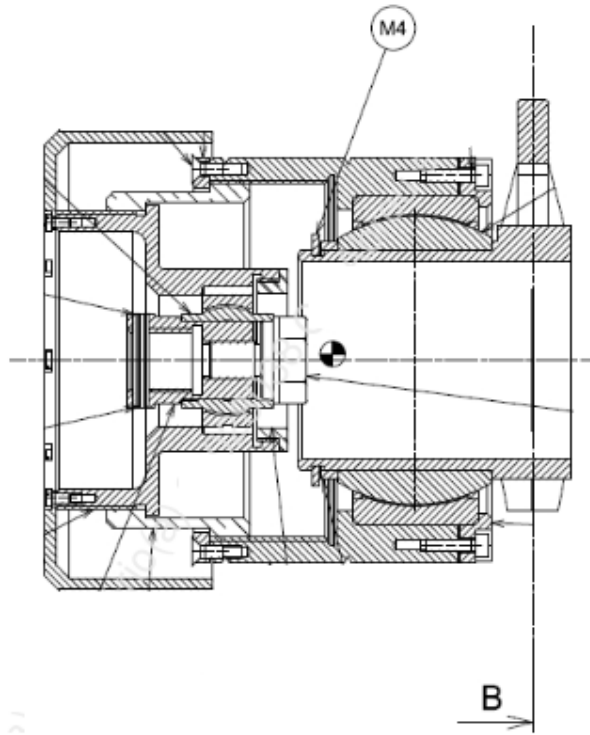

## ATTACHMENT D

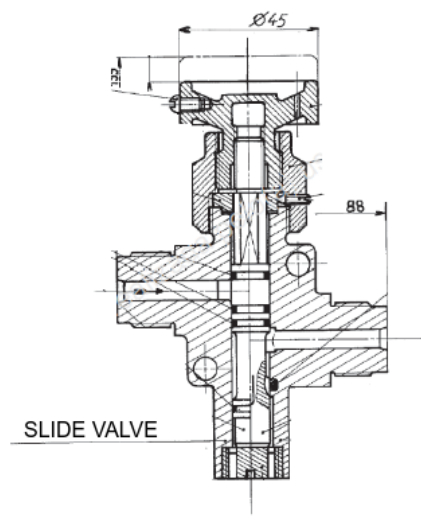

# ATTACHMENT E

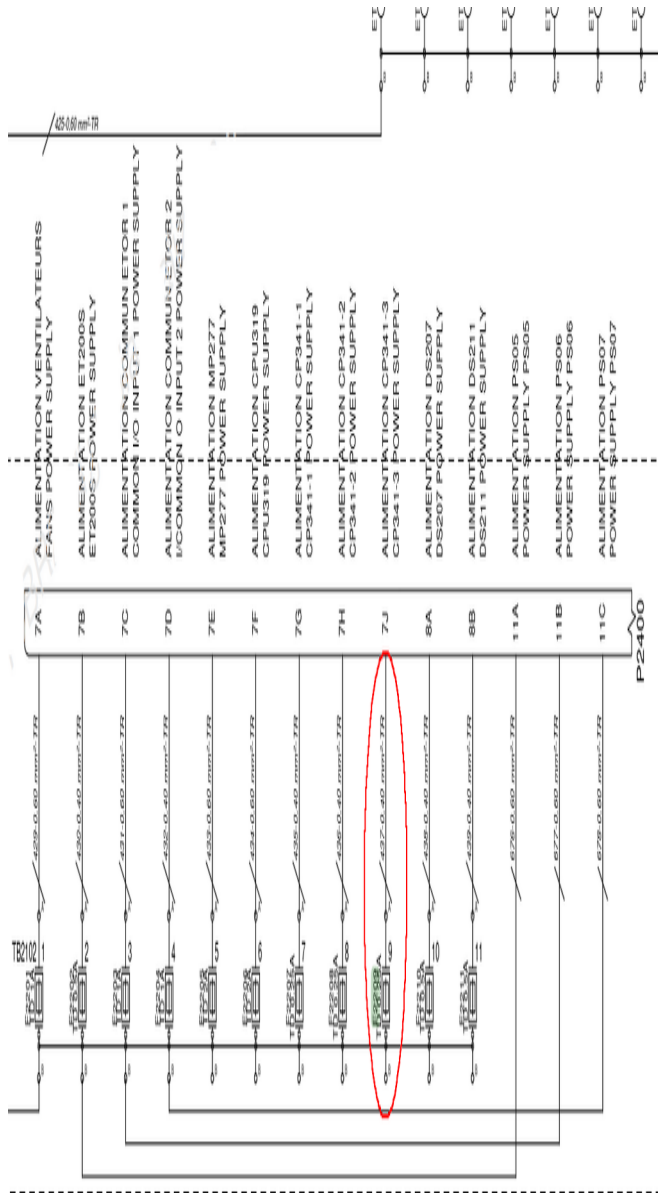

## ATTACHMENT F

FOR

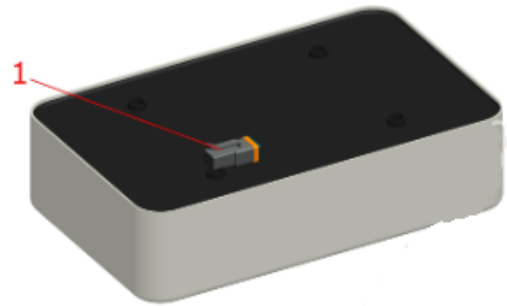

# ATTACHMENT G

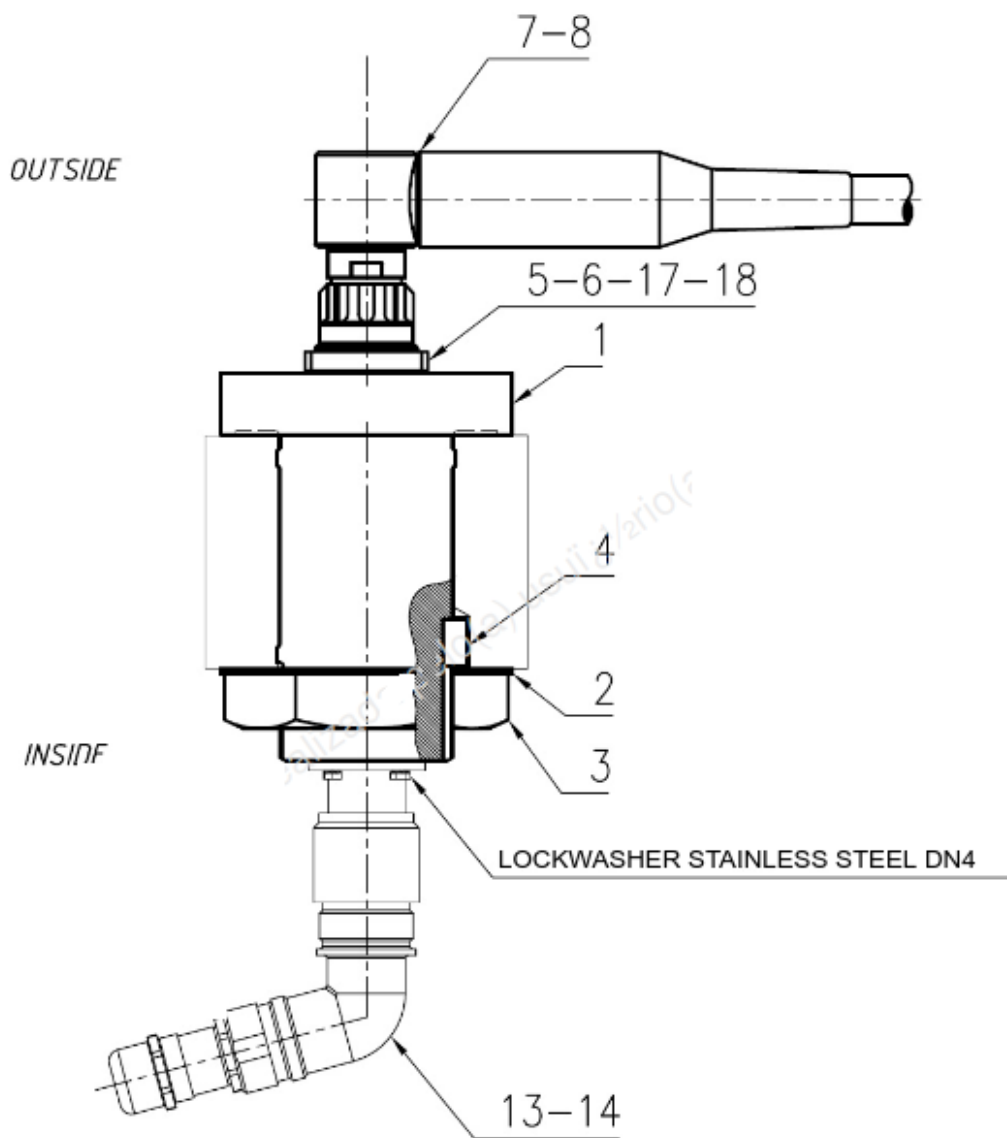

## ATTACHMENT H

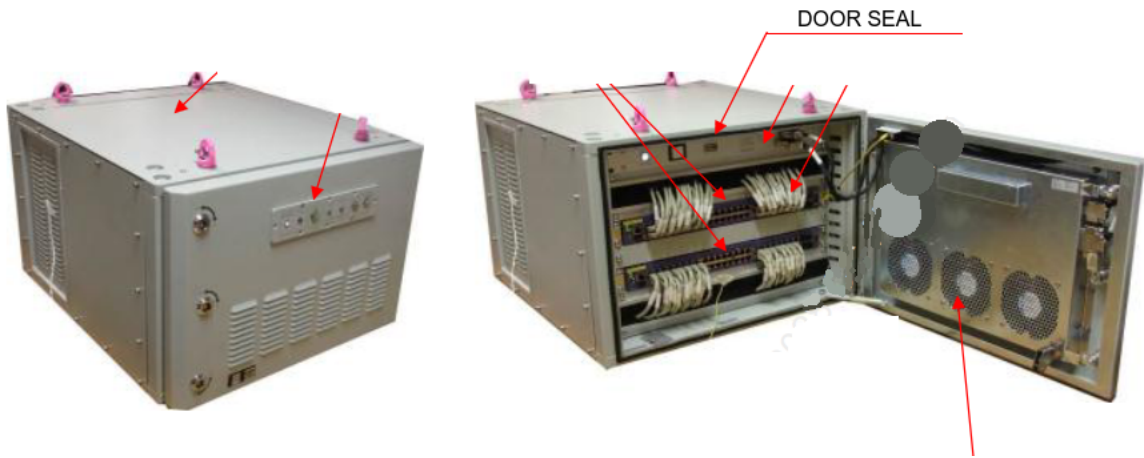

# ATTACHMENT I

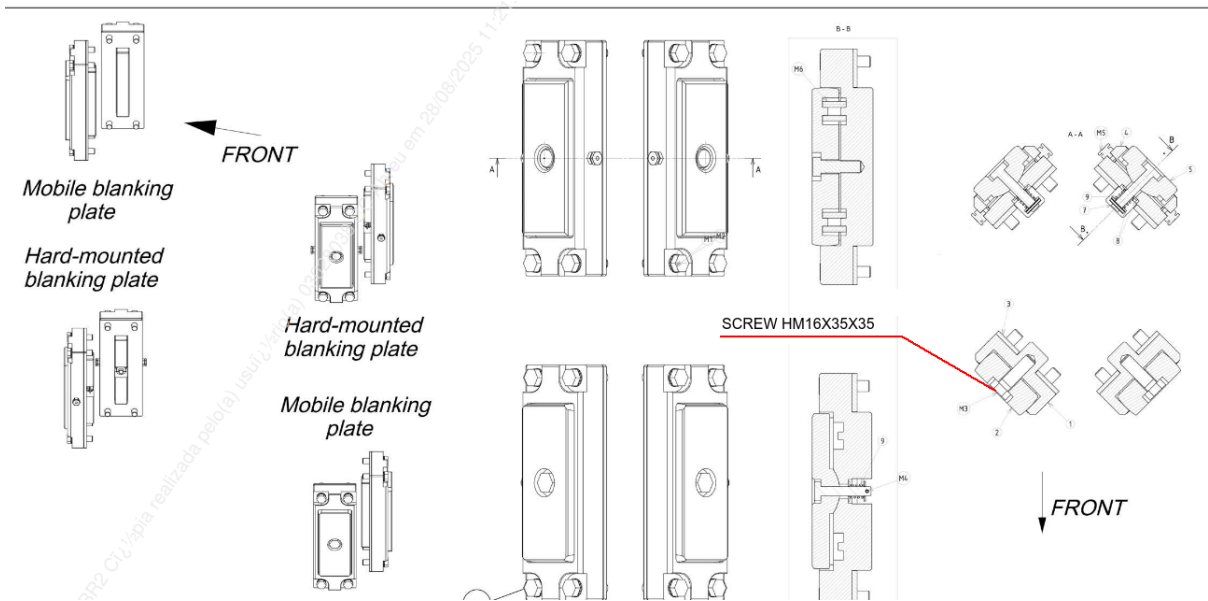

## ATTACHMENT J

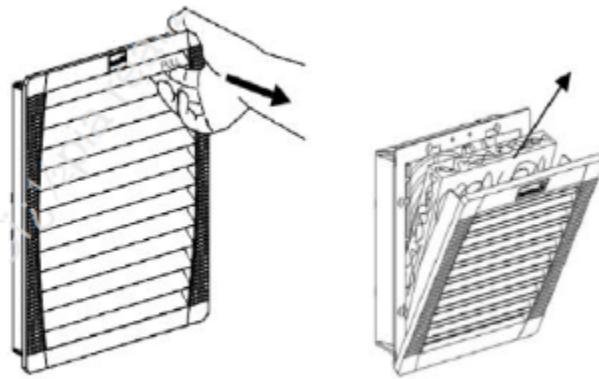

# ATTACHMENT K

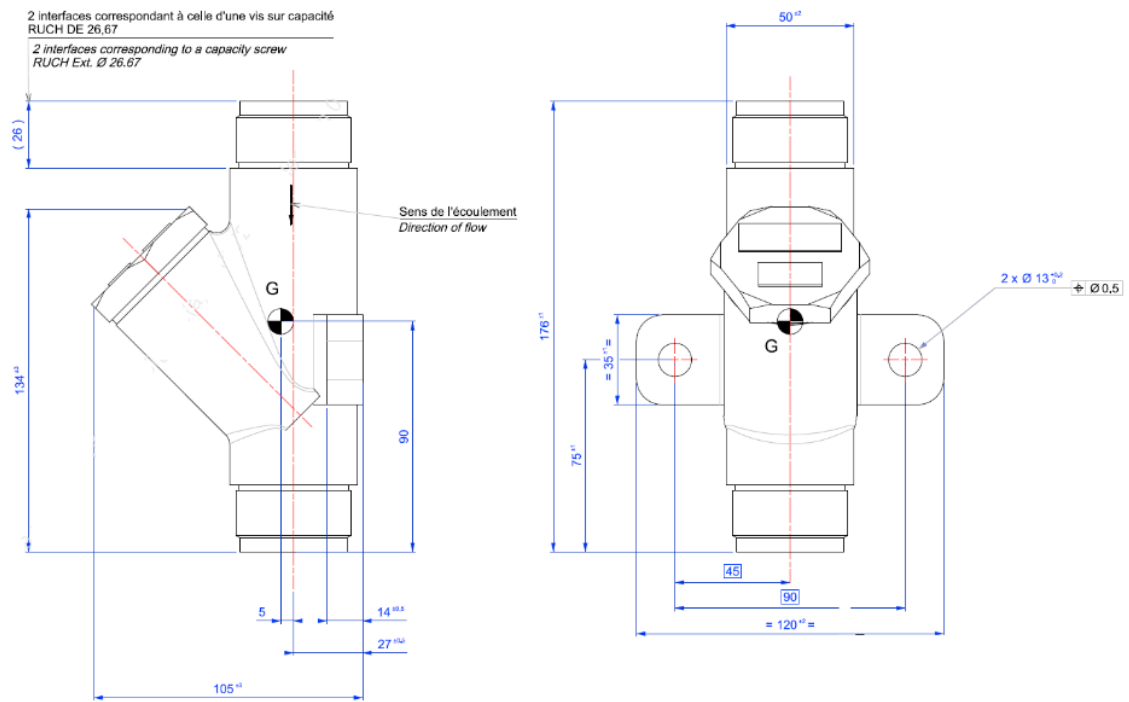

## ATTACHMENT L

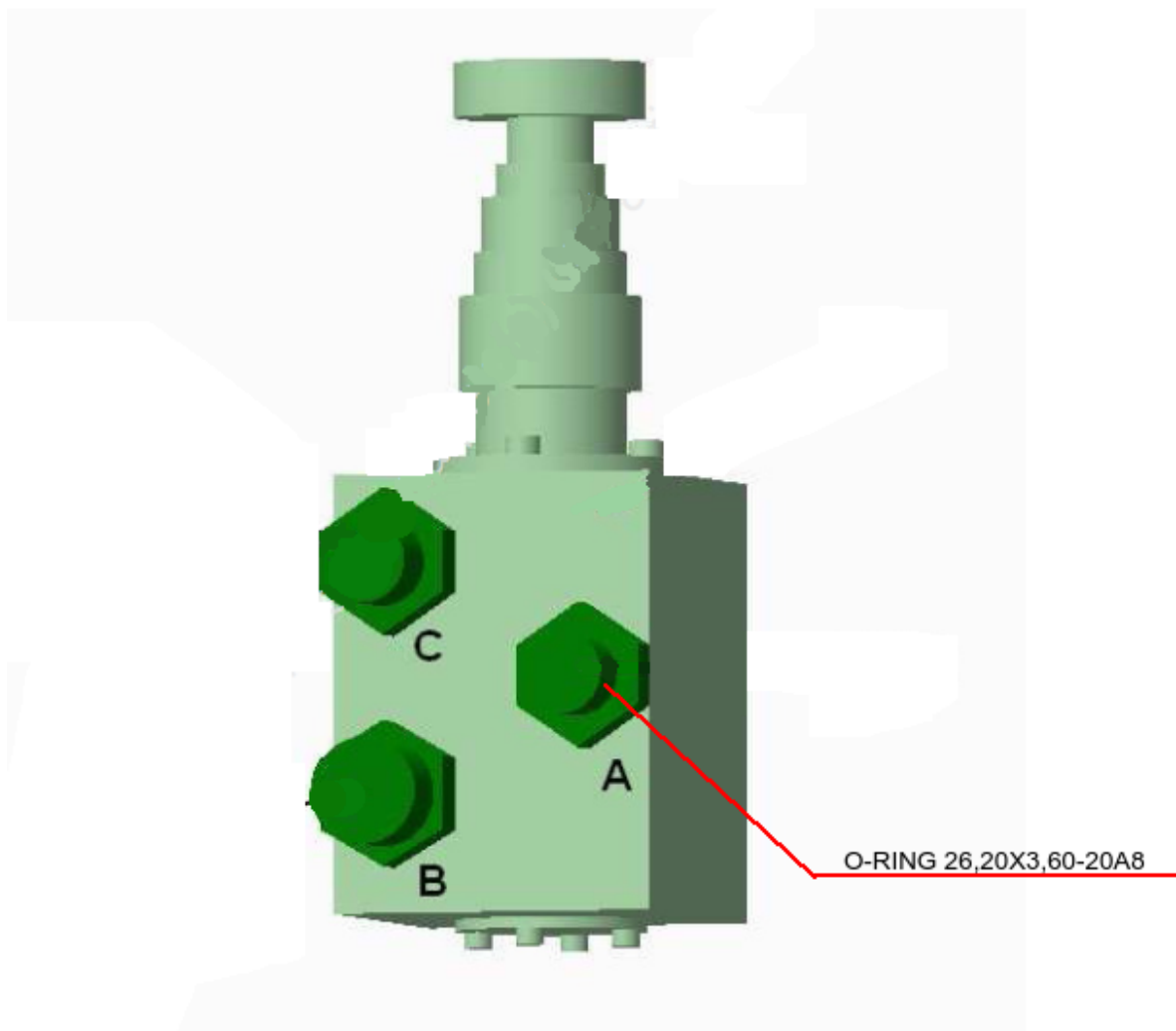

## ATTACHMENT M

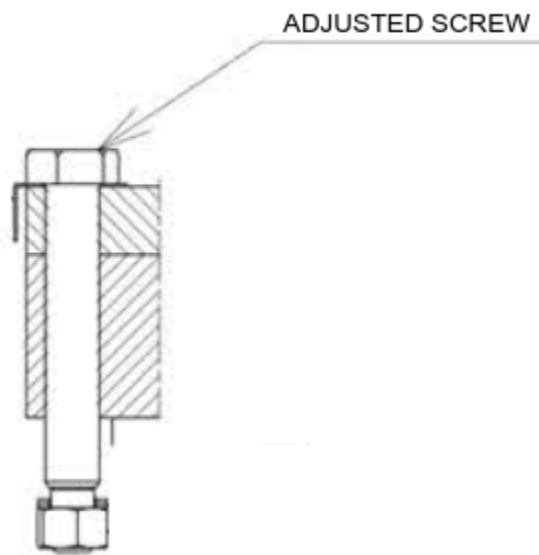

## ATTACHMENT N

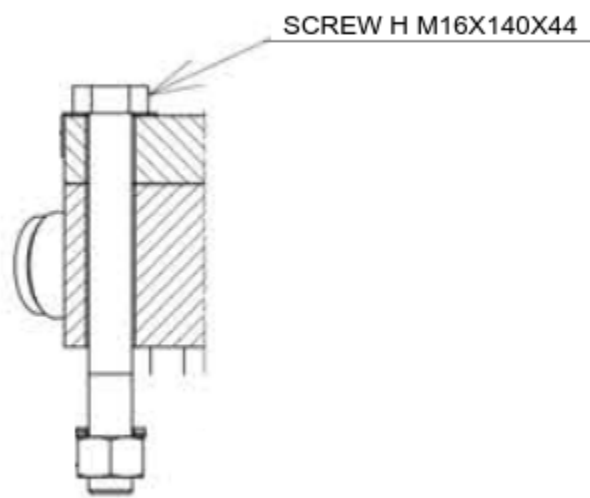



# ATTACHMENT P

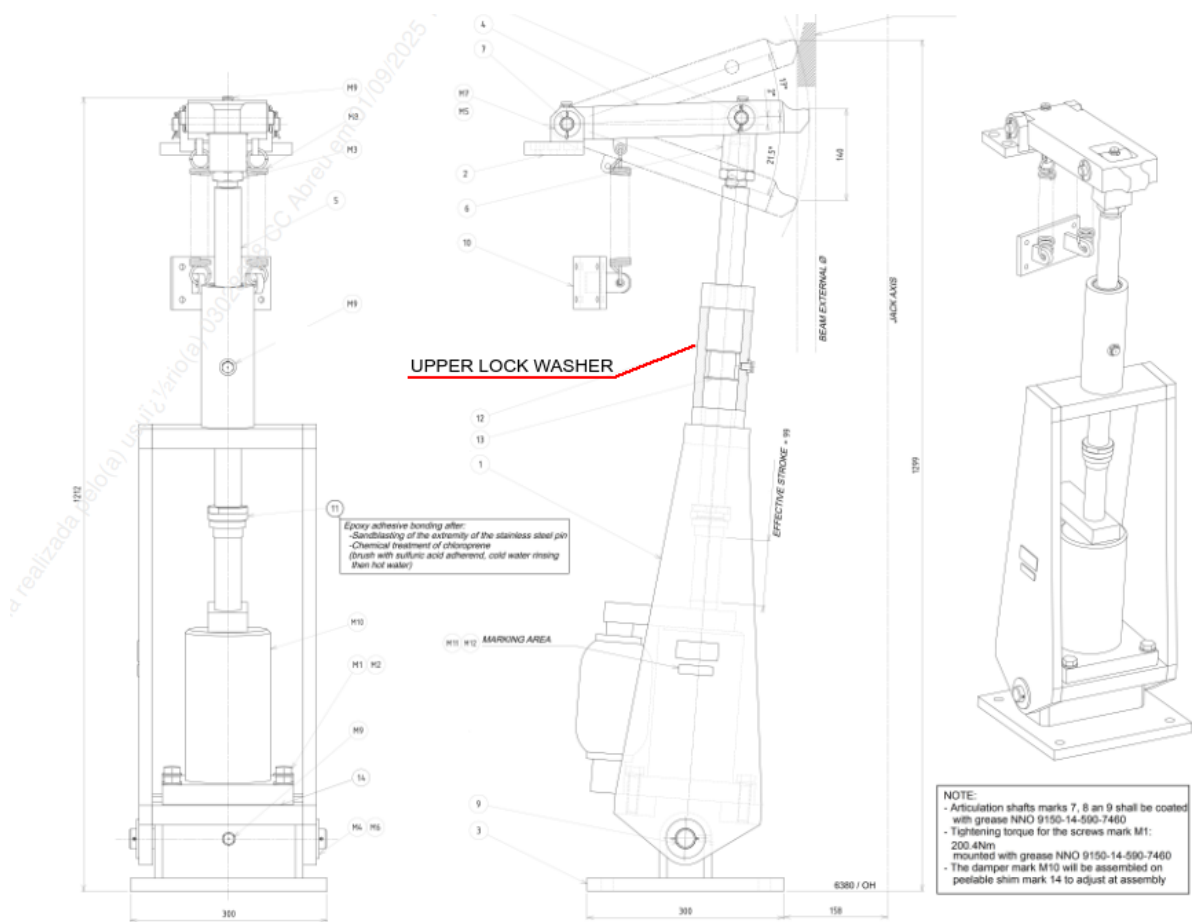



# ATTACHMENT R

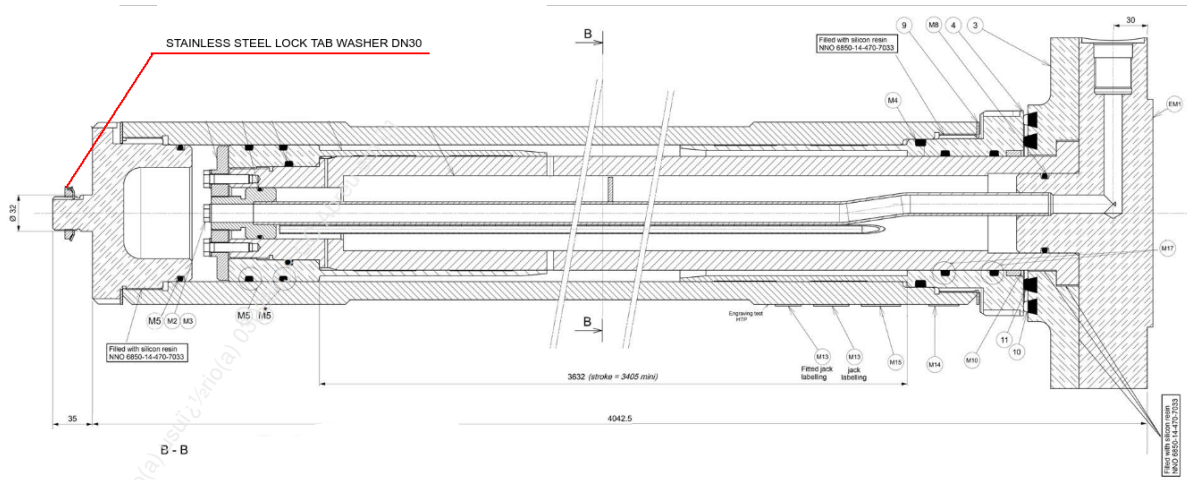



# ATTACHMENT T

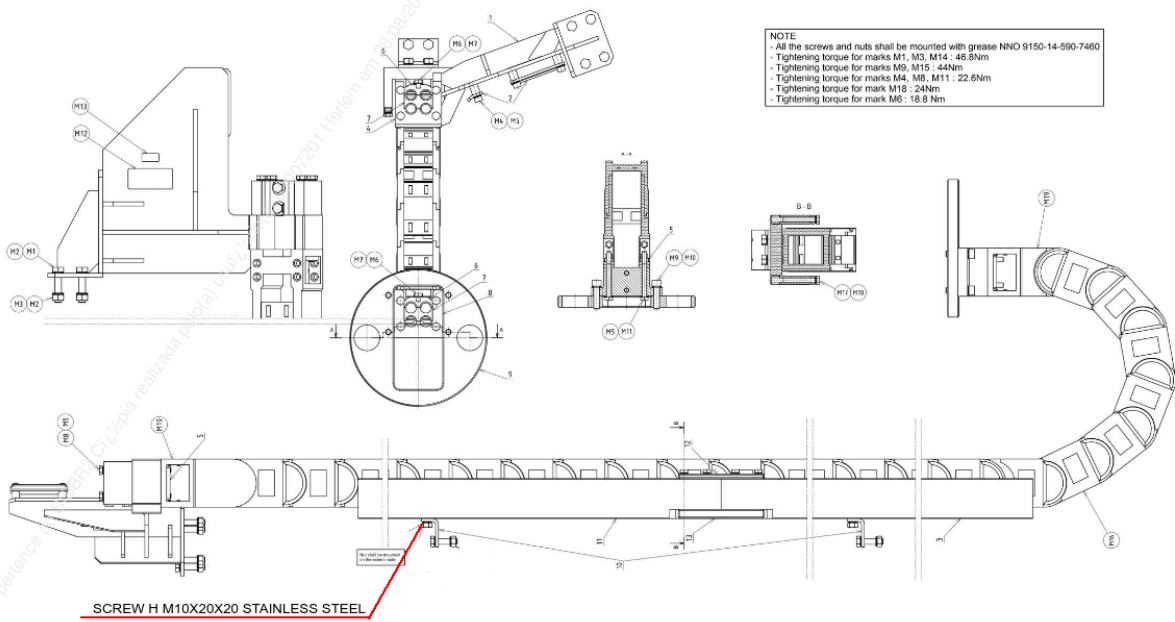

# ATTACHMENT U

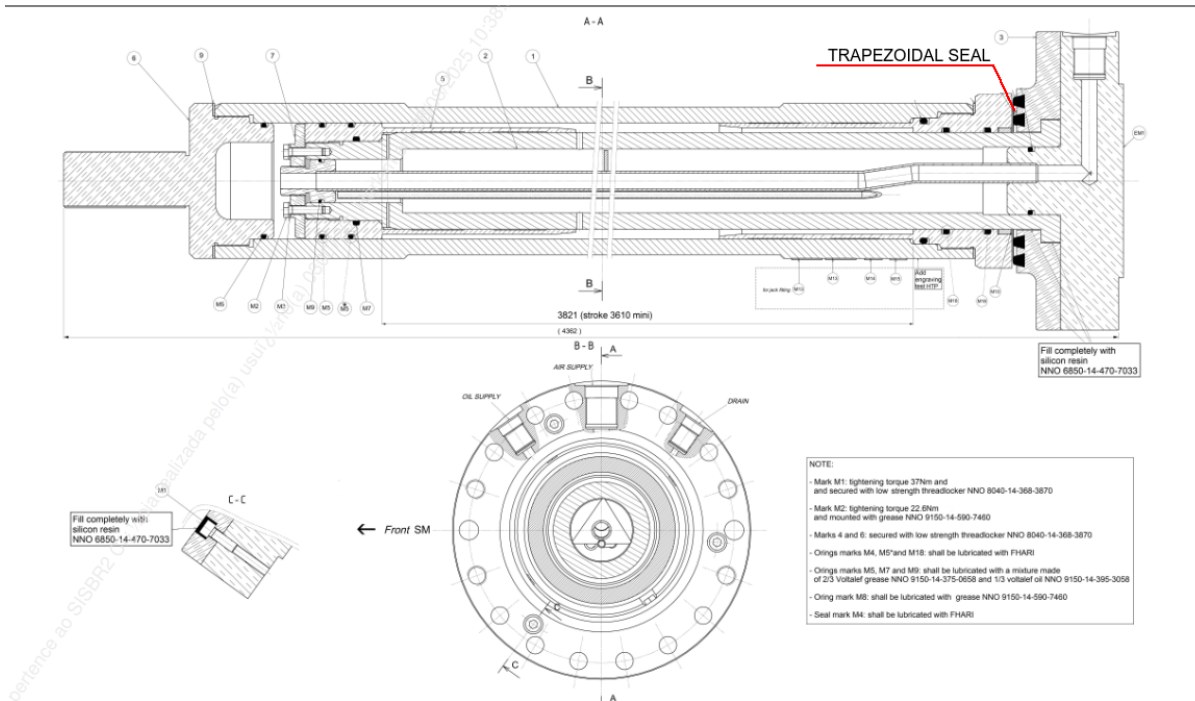

# ATTACHMENT V

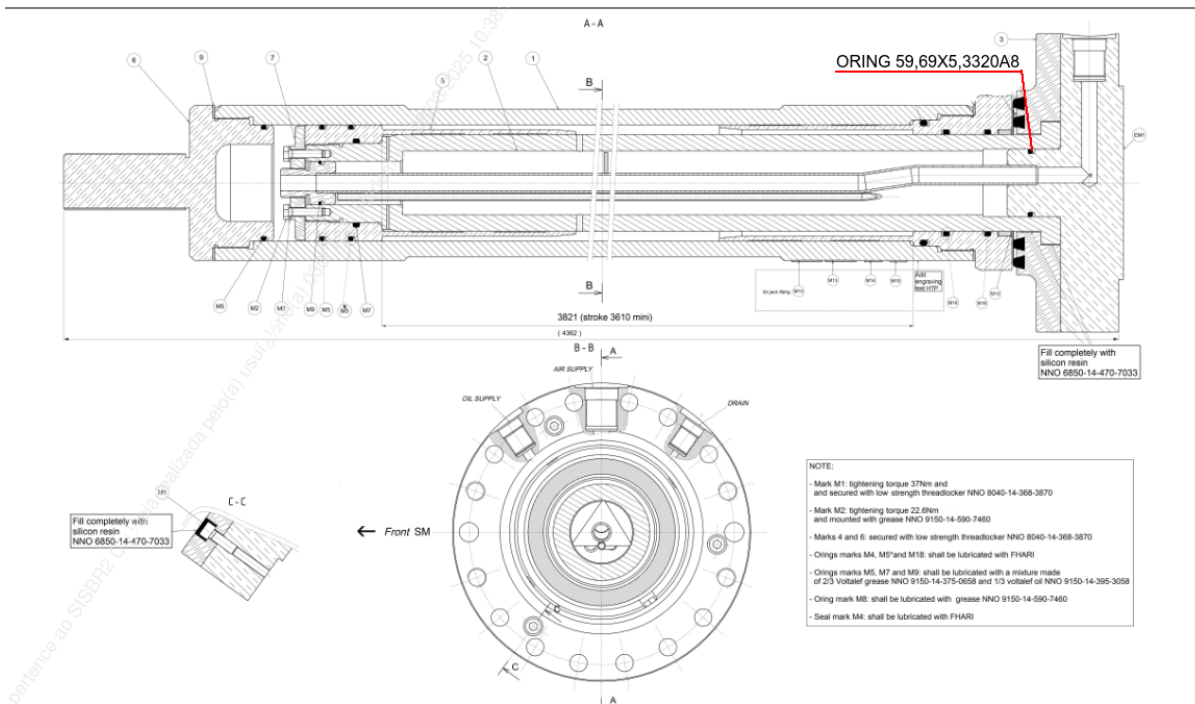

# ATTACHMENT X

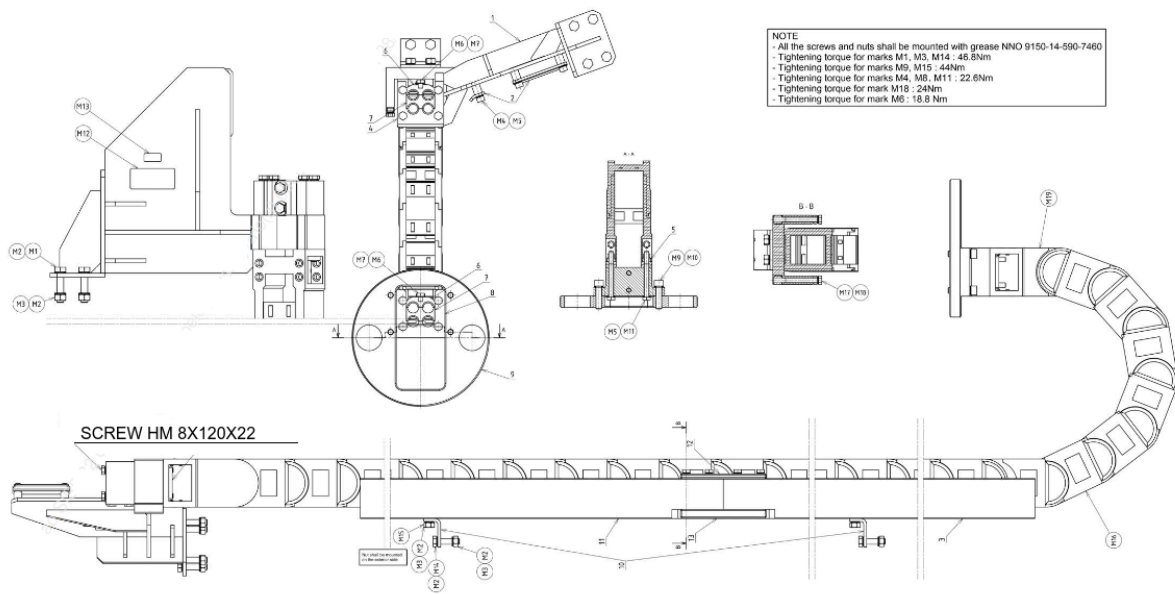

LEANDRO JUSTINO DE ABREU  
Lieutenant-Commander  
Ship Manager  
ASSINADO DIGITALMENTE